



AIR CONDITIONING



REFRIGERATION



HEATING



# macerator 4L & 10L

## CONDENSATE REMOVAL PUMP

Designed to collect defrost water from multiple refrigeration cabinets. The internal filter blade prevents the pumps from clogging, allowing longer intervals between maintenance visits.



780L/h max. flow



8.5m max. rec. head  
(flow rate 80L/h)

### KEY FEATURES

- Internal filter blade
- High flow & head
- Hi-level safety switch

### SUITABILITY

- Single and multiple refrigeration units
- ✓ **Perfect for...** handling food waste that may pass through the pump

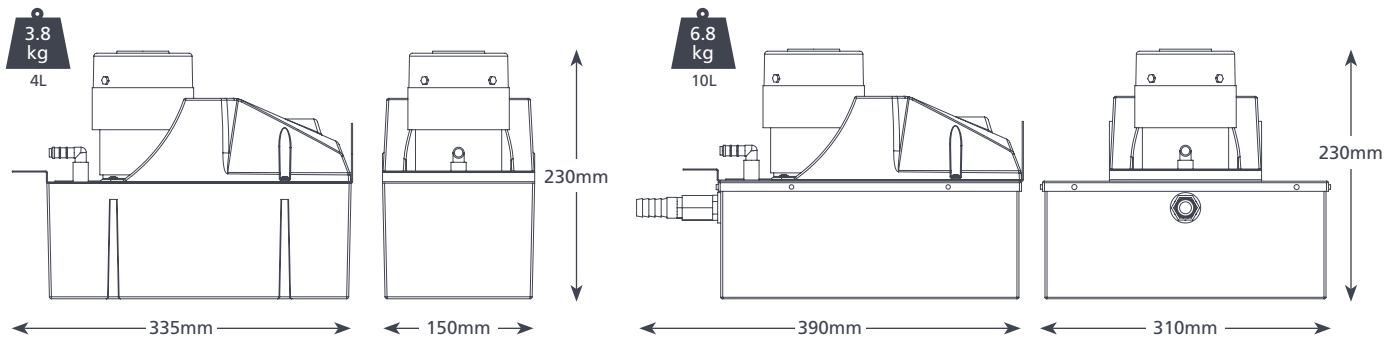

MACERATOR 4L & 10L SPECIFICATIONS	
Max. flow	780L/h @ 0 head
Max. rec. head	8.5m
Tank capacity	4L & 10L
Sound level@1m	64dB(A)
Power supply	230 VAC, 0.38A, 50/60Hz
Rated	Non continuous
Class	I appliance
Max. unit output	n/a
Max. water temp	40°C / 104°F
Inlet/outlet	x2 40 & 55mm in, 10mm out
Additional inlet	3/4" in tank (10L only)
IP Protection	4L & 10L: IP21
Safety switch	4.0A Normally closed
Thermal protection	✓
Self priming	n/a

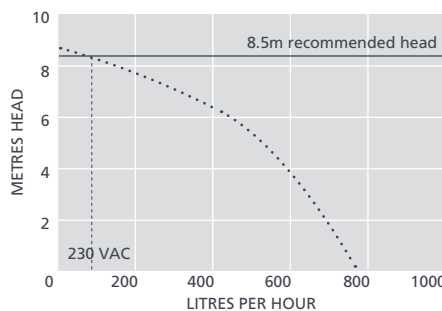

SUGGESTED XTRA ACCESSORIES	
Description	Part No.
1 Amp Fuse	FP2620
Tube To Soil Stack Adaptor	FP2038
Vinyl Tube Braided 3/8" (10mm)	AX5101
StayClean Strips	FP1248

**Xtra** For more installation accessories take a look at our Aspen Xtra range

MACERATOR 4L & 10L OPTIONS	
Macerator 4L	FP2305
Macerator 10L	FP2307

IN THE BOX
Macerator 4L or 10L pump (including hard wired 2m power cable) • Install manual

Download manual at [aspenspumps.com](http://aspenspumps.com)

Information correct at time of going to press.

